

OWNER'S MANUAL

Model: ATV-DMS-12V (5301845)

(Electric Dry Material Broadcast Spreader for ATV Mounting)

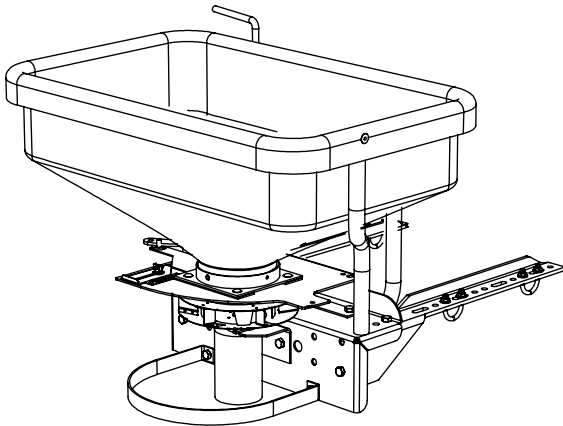

**BEFORE RETURNING THIS PRODUCT
FOR ANY REASON, PLEASE CALL**

1-800-831-0027

**IF YOU SHOULD HAVE A QUESTION OR
EXPERIENCE A PROBLEM WITH YOUR
FIMCO INDUSTRIES PRODUCT:**

1-800-831-0027

**BEFORE YOU CALL, PLEASE HAVE THE
FOLLOWING INFORMATION AVAILABLE:
SALES RECEIPT & MODEL NUMBER. IN MOST
CASES, A FIMCO INDUSTRIES EMPLOYEE CAN
RESOLVE THE PROBLEM OVER THE PHONE.**

General Information

Thank you for purchasing this FIMCO product. The purpose of this manual is to assist you in operating and maintaining your dry material spreader. Please read it carefully, as it furnishes information which will help you achieve years of trouble-free operation. The FIMCO dry material spreader is used to spread all types of dry material, such as fertilizer, seed, bait, powders, granular insecticides, granular fungicides, granular herbicides, pellets, and ice melting pellets.

Warranty/Parts/Service

Products are warranted for one year from date of purchase against manufacturer or workmanship defects.

Commercial users have a 90 day warranty.

Your authorized dealer is the best source of replacement parts and service. To obtain prompt, efficient service, always remember to give the following information...

- Correct Part Description and/or part number.
- Model of your spreader.

Part descriptions and part numbers can be obtained from the illustrated parts list section(s) of this manual.

Whenever you need parts or repair service, contact your distributor/dealer first. For warranty work, always take your original sales slip, or other evidence of purchase date, to your distributor/dealer.

Technical Specifications

- Hopper Capacity: 2.2 Cu. Ft.
- Spread Width: 5 Feet to 50 Feet
- 12 Volt Motor with Variable Speed Control (VSC)
- Stainless Steel 6-Blade Radial Fan
- Approximate Shipping Weight = 50 lbs.

Tools required for assembly:

9/16" socket wrench, 9/16" open/box-end wrench

Operating Safely

Read this owner's manual before you assemble or operate the Dry Material Spreader.

Use eye, hand, and breathing protection appropriate to the materials that you are spreading. Read the manufacturers or suppliers labels for proper protective equipment

Read and follow the manufacturers' instructions and notes for spreading and handling materials used for spreading.

Do not allow anyone to ride on or sit with you while operating the spreader.

Do not modify Dry Material Spreader or safety devices and guards.

Assembly

1. Remove all parts and hardware packages from the carton. Lay out all parts and hardware and identify using the illustrations later in this manual.
2. Insert gate On/Off handle into lower handle bracket on spreader frame and apply pressure upward to compress the spring.
 - A. Locate the friction washer (garden hose washer) over the pin on the slide gate, insuring that the hole in the end of the gate open link is located over the pin on the slide gate arm on the spreader, and the pin is in the handle bracket.
 - B. Operate the gate On/Off handle to check that the slide gate moves and stays in the full open and closed positions.
 - C. If the slide gate moves freely or seems to stick, slightly bend slide gate arm up to tighten, or down to loosen the action.



www.fimcoindustries.com

1000 FIMCO Lane, P.O. Box 1700, North Sioux City, SD 57049
Toll Free Phone: 800-831-0027 : Toll Free Fax: 800-494-0440

Form No. 1827 [5008155 (09/09)] Printed in the U.S.A.

Installation

1. Determine which mounting holes on the mounting bracket weldment need to be used that will fit best on the vehicle rack. Use the widest mount holes possible on the spreader's frame.

2. Attach the spreader's mounting brackets to the vehicle's rear rack using the hardware provided.

3. Use 12V motor controller (battery cable) clip to connect directly to the battery. Connect the red clip and red wire directly to the positive (+) terminal. Connect the black clip and black wire directly to the negative (-) terminal.

Route 12V motor controller battery cable and 12V motor controller (motor cable) securely and carefully to prevent damage from moving parts and exhaust heat.

Turn the Motor Controller switch to the OFF position, before connecting to the motor cable.

Set the Motor controller to the number "5", and switch the fan motor on. The fan should run at ½ speed. Rotate to number "10" for full fan speed, and then rotate to number "1" for slowest fan speed.

This should be done without material in the Hopper and gate slide closed.

Operation

Replace or repair loose or missing components
Operate controls and switches to make sure they respond correctly
Conditions of Weather and terrain must be considered when setting spreader. Do not spread on windy days, with light weight materials such as grass seed or powders.
Protective clothing must be worn in some cases.

1. Determine vehicle speed:

If vehicle does not have a speedometer, determining speed can be accomplished by marking off 100, 200, or 300 feet.

The speed chart indicates the number of seconds it takes to travel the distances.

Using a watch or stop watch for time, travel into and out of marked distance for a more accurate application speed.

See the recommended speeds/settings later in this manual.

Speed in M.P.H. (Miles per Hour)	Time Required in Seconds to Travel a Distance of:		
	100 Ft.	200 Ft.	300 Ft.
1.0	68	136	205
2.0	34	68	102
3.0	23	45	68
4.0	17	34	51
5.0	14	27	41
6.0	11	23	34
7.0	9.7	19	29
8.0	8.5	17	26
9.0	7.6	15	23
10.0	6.8	14	20

$$\text{SPEED (MPH)} = \text{Distance (Ft.)} \times 60 / \text{Time (seconds)} \times 88$$

2. Set Electronic Speed Control:

Adjust speed control to set the spread width. The highest fan speed will spread the widest pattern.

After adjusting the speed control to the desired width for the material you are using. Leave the dial on this setting and use the power switch to turn the fan on and off. When operating speed control at less than 2, remove agitator clip.

3. Set Opening Gauge Control:

Refer to the settings chart for the proper settings.

Loosen wing nut and move gate slide gauge to the desired setting. Tighten wing nut.

4. Adjust Pattern Adjust Ring Position to Center Spread Pattern:

If the spread pattern is off-center, adjust by rotating the pattern adjusting ring. This adjustment is only required if the material density has dramatically changed.

Pattern adjust ring has been set at the factory for UREA.

Caution: Making adjustments with spinner running is unsafe. Never adjust pattern ring with spinner powered. Disconnect power at the battery or speed control or motor before doing any pattern adjusting.

- Loosen worm gear clamp only enough to allow pattern adjust ring to be removed with slight force.

- Adjust pattern ring to re-center spread pattern. If pattern is too heavy to the driver's right, rotate the pattern adjust ring clockwise (as viewed from the top) until the pattern is even. If the pattern is heavy on the driver's left, rotate the pattern adjust ring counter-clockwise (as viewed from the top) until the pattern is even.

- Retighten the worm gear clamp to a snug fit. **DO NOT OVER-TIGHTEN!**

- To return the pattern adjust ring to the factory setting, simply align the pattern adjust ring to the center of the mounting plate, **as pictured below (**)**

5. Do not fill and transport over long distances. This will result in material packing and caking. Remove and clean all material at the end of your spreading day.

Cleaning/Storing

1. Remove and clean all material from the hopper.

2. Rinse inside and outside of hopper and dry before storing.

3. Motor and Motor Controller are water resistant. Do not submerge into water, or use high pressure sprayers to clean.

4. The spreader should be stored in a dry area.

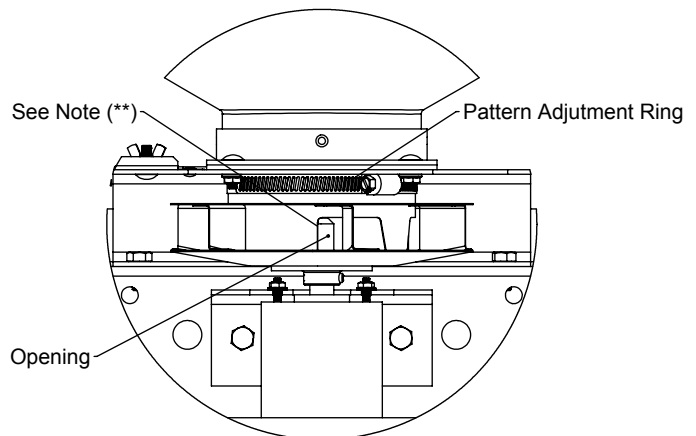

Exploded View:
ATV-DMS-12V (5301845)

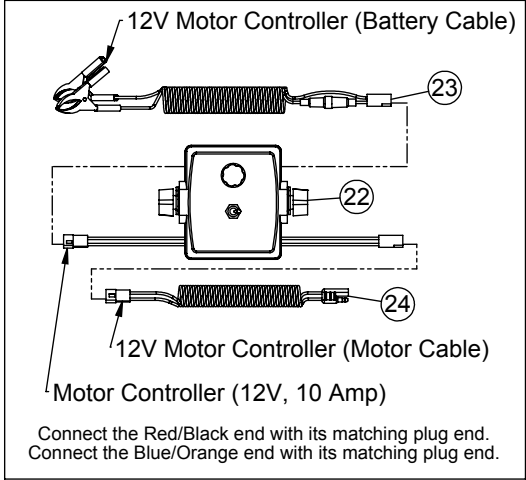
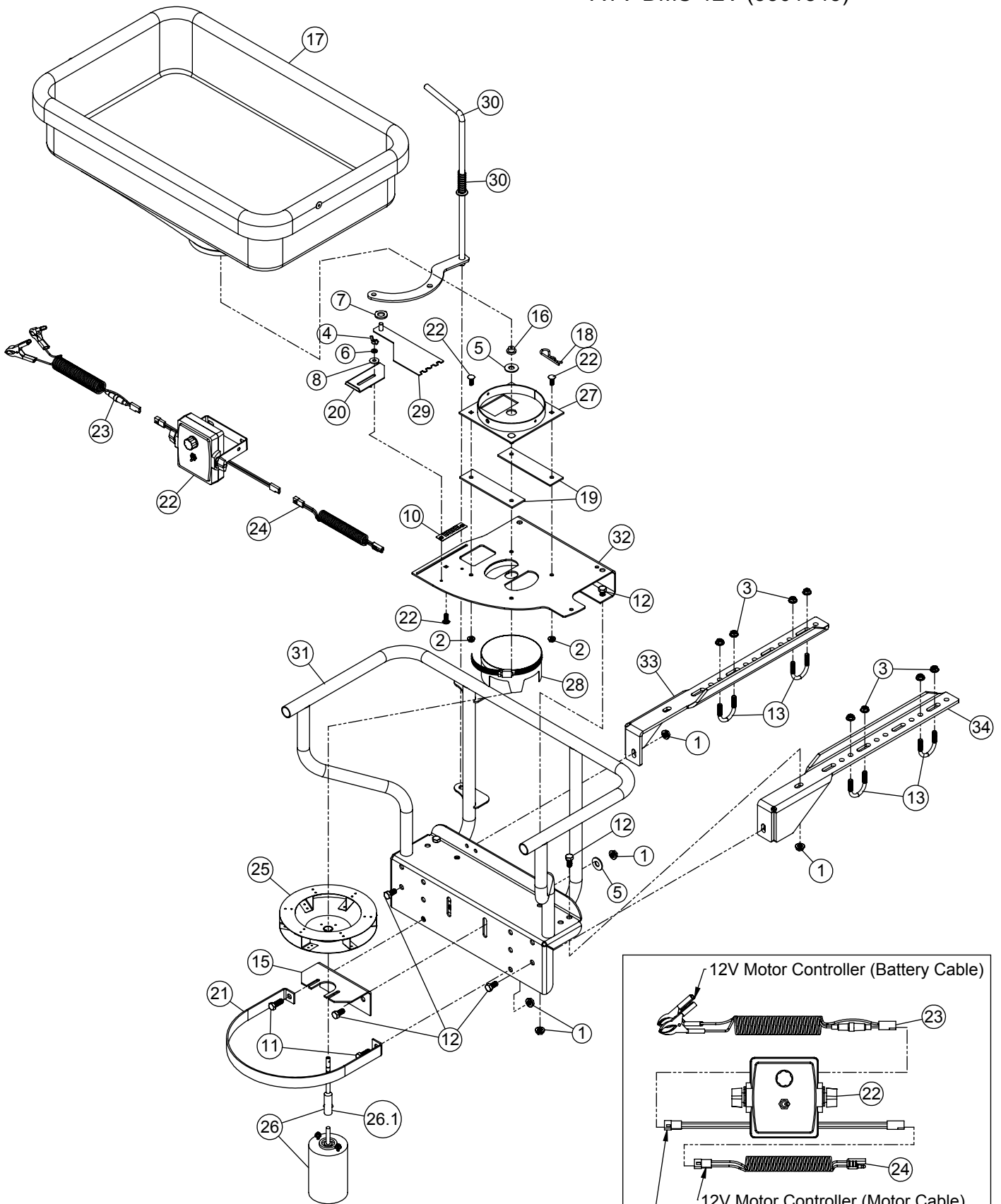

Parts List: ATV-DMS-12V (5301845)

Item No	Part Number	Qty	Description	List Price
1	5006259	10	3/8"-16 Hex Whiz (Flange) Locknut	.25
2	5006306	4	1/4"-20 Hex Whiz (Flange) Locknut	.05
3	5006307	8	5/16"-18 Hex Whiz (Flange) Locknut	.25
4	5006320	1	Wing Nut, 1/4"	.25
5	5016030	3	Flatwasher, 3/8"	.25
6	5016035	1	Lockwasher, 1/4"	.25
7	5016066	1	Garden Hose Washer	.20
8	5016114	1	Flatwasher, 1/4"	.02
9	5019267	1	Spring	
10	5027132	1	Gate Scale Plate	
11	5034079	2	H.H.C.S., 3/8"-16 x 1"	.25
12	5034099	8	H.H.C.S., 3/8"-16 x 3/4"	.50
13	5034220	4	Round U-Bolt, 5/16"-18 x 1 5/16" x 1 3/4"	.50
14	5034481	5	Carriage Bolt, 1/4"-20 x 3/4"	
15	5038754	1	Motor Mount Bracket	
16	5075020	1	Grommet/Dry Spreader	
17	5083007	1	Hopper (ATV-DMS-12V)	
18	5101065	1	Hair-Pin Cotter (0.120" Dia.)	.40
19	5127198	2	Plastic Spacer/Guide	
20	5131073	1	Gate Stop	
21	5133267	1	Safety Strap	
22	5157208	1	Motor Controller (12 Volt, 10 Amp)	
23	5157210	1	12V Motor Controller (Battery Cable)	
24	5157211	1	12V Motor Controller (Motor Cable)	
25	5160003	1	Spinner	
26	5275840	1	12 Volt Motor w/Shaft	
26.1	5024115	1	Dry Spreader Motor Spindle	
27	5275923	1	Hopper Base/Ring Plate Weldment	
28	5275924	1	Pattern Adjusting Ring Weldment	
29	5275925	1	Slide Gate Weldment	
30	5275926	1	Gate On/Off Handle Weldment	
31	5275928	1	Frame Weldment	
32	5275950	1	Mounting Plate Weldment	
33	5275995	1	Spreader Mounting Bracket Weldment (LH)	
34	5275996	1	Spreader Mounting Bracket Weldment (RH)	

(List Prices are Subject to Change)

Troubleshooting Guide		
Symptom	Possible Cause	Action
Spreader Motor Does Not Run	1. Loose or corroded connection 2. Speed Control Light is OFF 3. Loose battery connection 4. Broken spreader wiring 5. Over or Under voltage	1. Clean, check, and reconnect 2. Check fuse. Replace if necessary 3. Adjust battery clamp contact 4. Replace or repair damaged wiring 5. Power to harness connected to aux. circuit; Connect direct to battery
Erratic Spread Pattern	Spinner Shaft Set Screws Loose	Tighten Set Screws
Gate will not close or open	Fertilizer Around Gate Slide	Remove slide gate weldment and clean after emptying hopper of material.
Gate will not stay open or closed	Friction washer is lost or worn	Replace friction washer.
Inline Fuse Body gets Hot Inline Fuse keeps blowing	Barrel fuse is not making direct contact with wire buttons	Make sure spring in fuse body is positioned behind the wire button. Hold top half of the in line fuse body next to speed control connect, and turn the bottom half of the in line fuse body

Settings & Charts

Dial Setting	Spread Width (Feet)
1	5
2	7.5
3	12
4	20
5	25
6	30
7	35
8	40
9	45
10	50

Ice Melt			
Ounces/Square Yard	lbs/1000 Sq. Ft.	Gate Setting	Materials
2	15-30	4.5	Freez Gard
2 to 4	15-30	4 to 5.5	Peladow
2 to 4	15-30	4.5 to 5.5	Dead Sea Works Ice Melting De-Icer
2 to 4	15-30	4.5 to 5.5	MAG Ice Melting Pellets
2 to 4	15-30	4.5 to 5.5	Ice No Mor
1/4 to 1	2-8	2 to 3.5	Professional Ice Melter
2 to 4	20-40	4 to 6.5	Professional Ice Melter
2 to 4	20-40	4 to 6	EC Grow lightning Fast
2 to 4	20-40	3.5 to 5.5	Thaw Master
2 to 4	20-40	4 to 6	Kansas Medium Rock Salt
1/4	2 1/2	2	Snowplow
8	80	10	Snowplow
8	80	9	Safe Step

Note: 3 mph and 5 foot spread width, remove agitation clip with Ice Melt product when using speed dial setting at less than 4.

(Settings & Charts)

Grass Seed		
lbs/1000 Sq. Ft.	Gate Setting	Materials
4	7	Master Turf Ultimate Tall Fescue Blend
8	9.5	Master Turf Ultimate Tall Fescue Blend
5	7.5	Pennington Master Turf High Traffic Lawn Seed Mixture
10	9.5	Pennington Master Turf High Traffic Lawn Seed Mixture
4	7.5	Pennington Master Turf Shady Traffic Lawn Seed Mixture
8	9.5	Pennington Master Turf Shady Traffic Lawn Seed Mixture
5	7.5	Pennington Master Turf Sun and Shade Lawn Seed Mixture
10	9.5	Pennington Master Turf Sun and Shade Lawn Seed Mixture
5	7.5	Rebels Supreme Blend Grass Seed for Sun and Shade
10	9.5	Rebels Supreme Blend Grass Seed for Sun and Shade
2	4.5	Scotts Classic Grass Seed Fall Grass Seed Mix
4	7	Scotts Classic Grass Seed Fall Grass Seed Mix
1.1	2.5	Scotts Pure Premium Kentucky Bluegrass Mix
2.2	3.5	Scotts Pure Premium Kentucky Bluegrass Mix
1.25	4.5	Scotts Pure Premium Sun and Shade Grass Seed Mix
2.5	5.5	Scotts Pure Premium Sun and Shade Grass Seed Mix
5	7.5	Sun and Shade Grass Seed Mixture
10	9.5	Sun and Shade Grass Seed Mixture
2	3	Wal Mart Gardens Kentucky Bluegrass Seed
4	4.5	Wal Mart Gardens Kentucky Bluegrass Seed
4	7.5	Wal Mart Gardens Kentucky 31 Tall Fescue
8	9.5	Wal Mart Gardens Kentucky 31 Tall Fescue
3	4	Bluegrass 98.5%
4	4.5	Bluegrass 98.5%

Note: 3 mph and 10 foot spread width.

This is information off the sticker on the hopper.

lbs/1000 Sq. Ft.	0.6	0.7	0.8	1	1.5	2	3.5	4.5	6.0	7.5	9.0	10.0	11.0	13.0	15.0	17.0
Flow Control Setting	1	2	2.5	3	3.5	4	4.5	5	5.5	6	6.5	7	7.5	8	9	10
Operation Instructions	* USE APPLICATION INFORMATION ON BAG, FIND CALIBRATION SETTING (ABOVE) AND SET GATE STOP TO CORRECT FLOW SETTING * IF SPREAD PATTERN IS OFF CENTER ADJUST PATTERN RING POSITION, SEE OWNER'S MANUAL * NOTE: ABOVE CALIBRATION SETTINGS HAVE BEEN DETERMINED USING UREA 46-0-0, 20 FOOT SWATH, AND 3 MPH (TRAVEL 88FT IN 20 SECONDS) * NOTE: CALIBRATION GUIDE SETTINGS IS TO BE USED AS A GENERIC GUIDE. FOR SPECIFIC PRODUCTS, SEE YOUR OWNER'S MANUAL															
INSTRUCCIONES DE OPERACION	· USE LA INFORMACIÓN SOBRE APLICACIÓN EN LA BOLSA, BUSQUE LA POSICIÓN DE CALIBRACIÓN (ARRIBA) Y FIJE LA PARADA DE LA PUERTA PARA CORREGIR LA CALIBRACIÓN DE LA CORRIENTE. · SI EL ORDEN DE LA DIFUSIÓN ESTA FUERA DEL CENTRO AJUSTE LA POSICIÓN DEL ANILLO DE ORDEN, REFIERASE AL MANUAL DE DUEÑO. · NOTAR: LAS POSICIONES DE CALIBRACIÓN DE ARRIBA HAN SIDO DETERMINADAS USANDO LA UREA 46-0-0, 20 DE FRANJAS DE PIE, Y 3MPH (VIAJANDO 88 PIES EN 20 SEGUNDOS). · NOTAR: LAS POSICIONES DE GUIA DE CALIBRACIÓN HAN DE USARSE SOLO COMO GUIA GENERAL. PARA PRODUCTOS ESPECIFICOS, REFIERASE A SU MANUAL DE DUEÑO.															

(Settings & Charts)

Turf Materials		
lbs/1000 Sq. Ft.	Gate Setting	Materials
10	6.5	All America All Purpose Fertilizer 10-10-10
3	4.5	Bayer Season Long Grub Control
2.4	4	Bayer Season Long Grub Control
3	4	Bayer Complete Insect Killer
2	3.5	Bayer Complete Insect Killer
3	3	Bayer Power Force Multi-Insect Killer
2	2.5	Bayer Power Force Multi-Insect Killer
4	4	EC Grow Premier Turf Fertilizer 25-3-10
3	4	Eliminator Ant, Flea, and Tick Killer Granules
2.5	3.5	Eliminator Ant, Flea, and Tick Killer Granules
2	3.5	Eliminator Ant, Flea, and Tick Killer Granules
2	3.5	Eliminator Fire Ant Killer Granules
2	4	Eliminator 5% Diazinon Killer Granules
7	5.5	Howard Johnsons All Purpose Fertilizer 8-8-8
7	5.5	Howard Johnsons All Purpose Fertilizer 10-10-10
7	5.5	Howard Johnsons All Purpose Fertilizer 12-12-12
5	5	Ironite 1-0-0
4	4	Klay Soft Pelletized Gypsum Soil Conditioner
3	3.5	Klay Soft Pelletized Gypsum Soil Conditioner
2	3	Klay Soft Pelletized Gypsum Soil Conditioner
4	5	Lesco Pre-M 0.86% Plus Fertilizer 25-0-7
4.2	4.5	Lesco Starter Fertilizer 18-24-12
4.2	4	Lesco Turf Fertilizer 24-2-11
4	4	Lesco Weed and Feed
8	7	Milorganite 6-2-0
16	8.5	Milorganite 6-2-0
3.2	4	Miracle-Gro Lawn Fertilizer Plu Weed Control 26-3-3
3.6	4	Miracle-Gro Starter Lawn Fertilizer 20-27-5
3.1	3.5	Miracle-Gro Starter Lawn Fertilizer 29-3-4
9.6	6	Ortho Lawn Insect Killer Granules
4.8	4	Ortho Lawn Insect Killer Granules
2.4	2.5	Ortho Lawn Insect Killer Granules
1.2	2	Ortho Lawn Insect Killer Granules
4	4.5	Ortho Max Insect Killer for Lawns
2	3.5	Ortho Max Insect Killer for Lawns
1	2.5	Ortho Max Insect Killer for Lawns
10	6.5	Parkers Super Soilite Lawn and Garden Fertilizer 10-10-10
6.5	5	Parkers Super Soilite Lawn and Garden Fertilizer 16-4-8

Note: 3 mph and 20 foot spread width.

Optional Equipment

Receiver Hitch Adaptors

Allows the use of receiver hitches on vehicle to attach Dry Material Spreader.

- 1 1/4" Receiver Option (5301902)
- 2" Receiver Option (5301901)

Rain Covers

Mounting Bars for Utility Beds

Turf Materials		
3.6	4	Pennington Lawn Starter Fertilizer 18-24-6
2	3	Real-Kill Multi-Purpose Lawn and Garden Insect Killer
2.5	3.5	Real-Kill Multi-Purpose Lawn and Garden Insect Killer
10	7.5	Ringer Lawn Restore 10-2-6
12.3	8	Sam's Choice Crabgrass Preventer 30-3-4
8.1	6.5	Sam's Choice Crabgrass Preventer 30-3-4
6	6	Sam's Choice Crabgrass Preventer 30-3-4
5.4	5.5	Sam's Choice Crabgrass Preventer 30-3-4
3	3.5	Sam's Choice Insect Control Plus Fertilizer 28-4-6
3.2	4	Sam's Choice Lawn Food 29-3-4
6	6	Sam's Choice Starter Fertilizer 20-27-5
3.6	4.5	Sam's Choice Starter Fertilizer 20-27-5
2.3	3	Scotts Grubex
3.1	4.5	Scotts Grubex Season Long Grub Control
2.3	4	Scotts Grubex Season Long Grub Control
1.4	3	Scotts Lawn Fungus Control
2.7	4.5	Scotts Lawn Fungus Control
3.6	4	Scotts Starter Fertilizer 20-27-5
5.9	5	Scotts Starter Fertilizer 20-27-5
2.7	4	Scotts Turf Builder 28-3-8
3.1	3.5	Scotts Turf Builder Lawn Fertilizer 29-3-4
2.7	4	Scotts Turf Builder with Summer Guard
2.9	4	Scotts Turf Builder Plus Weed Control
4.7	4.5	Scotts Winterizer 24-3-12
3.3	4	Scotts Winterizer 24-3-12
4.6	5	Sevin Lawn Insect Granules
2.33	4	Sevin Lawn Insect Granules
2.25	4	Sevin Lawn Insect Granules
3	4.5	Spectracide Grub Stop
3	2.5	Spectracide Traizicide Insect Killer Granules
3.6	4	Sta-Green Lawn Fertilizer 29-2-5
2	3.5	Sta-Green Lawn Weed Control
3.2	4	Sta-Green 200 Plus Weed and Feed 28-3-3
3.6	4	Sta-Green Starter Fertilizer 18-24-10
3.2	4	Sta-Green Weed and Feed 28-2-4
3	2.5	Vigoro Insect Control Plus Fertilizer
3.6	5	Vigoro Starter Fertilizer
3.5	4	Vigoro Turf Fertilizer 29-3-4
3	3.5	Vigoro Ultra Turf Winterizer 22-3-14
3.2	5	Vigoro Weed and Feed
3.2	4	Wal Mart Weed and Feed 28-3-3