

INSTRUCTIONS

REPAIR PARTS LIST AND WARRANTY INFORMATION

WPO17E, WPO17N MPO17E, MPO17N POLY, ELECTRIC DRINKERS

READ ALL DIRECTIONS CAREFULLY BEFORE BEGINNING INSTALLATION

⚠ WARNING ⚠



1. INSTALLATION MUST BE MADE AND MAINTAINED IN STRICT ACCORDANCE WITH NATIONAL/LOCAL PLUMBING AND NATIONAL/LOCAL ELECTRICAL CODES (CSA IN CANADA). INSTALLATION MUST BE MADE BY A QUALIFIED ELECTRICIAN. THE APPLICABLE PROVISIONS OF THE ABOVE MENTIONED CODES TAKE PRECEDENT. IMPROPER ELECTRICAL INSTALLATION AND MAINTENANCE MAY RESULT IN SERIOUS INJURY OR DEATH FOR PERSONNEL OR LIVESTOCK.
2. EACH ELECTRICAL UNIT MUST BE WIRED THROUGH A FUSED SWITCH BOX AND FUSED ACCORDING TO AMPS REQUIRED FOR EACH SPECIFIED ELECTRICAL UNIT. SEE EXHIBIT A. CANADIAN ELECTRICAL CODE--PART 1 REQUIRES LIVESTOCK WATERERS INSTALLED IN FEEDLOTS IN OPEN FEEDING AREAS TO BE GROUNDED BY A SEPARATE STRANDED COPPER GROUNDING CONDUCTOR OF AT LEAST NO. 6 AWG TERMINATING AT A POINT WHERE THE BRANCH CIRCUIT RECEIVES ITS SUPPLY.
3. THIS UNIT MUST BE GROUNDED TO A COPPER GROUND ROD 5/8" (1.6CM) DIAMETER BURIED AT LEAST 10 FEET (3.1 METERS) IN UNDISTURBED SOIL. SEE EXHIBIT A.

REPAIR PARTS LIST - See Exhibit J on PAGE 6 for location of parts

Ref. No.	Part No.	Description	Qty	Ref. No.	Part No.	Description	Qty
1	WP01710	2 Hole Drinker Lid, Pride of the Farm, Gray	1	15	OP119	O-Ring, 1-3/4 ID x 2-1/8 OD x 3/16	1
1	MP01710	2 Hole Drinker Lid, Brower, Gray	1	16	OP116P	3/4" Schedule 40 Male Adapter, Standard, PVC	1
2	WP01711	2 Hole Drinker Base, Blue	1	17	OP120	#11 Rubber Stopper	3
2	MP01711	2 Hole Drinker Base, Red	1		WPO1717	Heater Assembly includes Ref. No 15 and Ref. Nos. 18 thru 25	
3	OP210	1-1/2" NPT Plug, Plastic	1				
4	WP01714	Base Seal, 84"	1	18	OP279	Connector, 1/2 .375 - .5	1
	WP01718	Valve/Supply Line Assembly includes Ref. Nos. 5 thru 16		19	OP280	1-1/2 x 1/2 Bushing	1
5	VP123	Valve Assembly, 3/32 Orifice	1	20	OP281	1-1/2 x 1-1/2 Female Adapter	1
6	VP115	Adjusting Screw, 1/4-20, Plastic	1	21	WPO1721	1-1/2" x 13 5/8" Schedule 40 PVC	1
7	VA225P	Float Arm 1/4-20 x 1, Plastic	1	22	OP291	1-1/2" x 1-1/2" x 1 Slip Tee, Split	1
8	OP286	4" Dia. Float, Poly	1	23	OP118	1-1/2 MIP Adapter	1
9	OP114	3/4 x 3/4 x 3/4 Schedule 80 Tee, PVC	1	24	OP93	11" Tywrap	1
10	OP223	Plug, 3/4, Nylon	1	25	OP284	C250 Utility De-Icer	1
11	WPO1712	Riser Tube Assembly, 15"	1	15	OP119	O-Ring, 1-3/4 ID x 2-1/8 OD x 3/16	1
12	WPM212	3/4" PVC Pipe x 19-1/2" (supply tube)	1				
13	OP117SJM	1-1/4" Slip Joint Nut	1				
14	OP116	3/4" Schedule 40 Male Adapter, Machined, PVC	1				

MODEL NUMBER

The MODEL NUMBERS are: WPO17E, WPO17N, MPO17E, MPO17N Drinkers

WHEN ORDERING PARTS

- (1) Show MODEL NUMBER and NAME: Example - WPO17E Poly Drinker
- (2) Show PART NUMBER and FULL DESCRIPTION of part: Example - OP210 1-1/2" NPT Plug, Plastic

HOW TO ORDER PARTS

Repair parts may be ordered from your dealer.



PO BOX 2000 • HOUGHTON, IOWA 52631 • USA
PHONE 319-469-4141 FAX 319-469-4402

EXHIBIT A

NOTE: Check local codes.
Some jurisdictions require 2 grounds & rods.

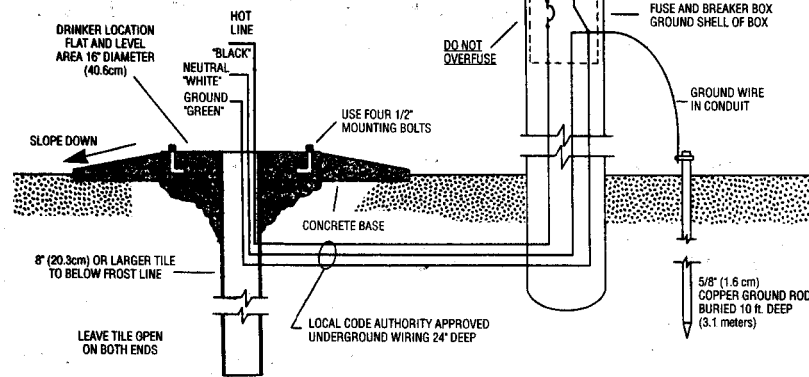

The following is intended to be used as a general guide for wiring electricity heated drinkers.

Paragraph 5, 6, and 7 are taken from ASAE Engineering Practice: ASAE EP 342. Safety for Electrically Heated Livestock Waterers, March 1995. Installation can only be completed by a qualified electrician.

5. Electrical Service

- 5.1 Service conductors should conform to the following:
 - 5.1.1 Conductors shall have sufficient ampacity for the load to be served.
 - 5.1.2 Overhead conductors shall have mechanical strength for the distance spanned. The conductors shall not be smaller than NO. 8 American wire gage, AWG, copper or NO. 6 AWG aluminum or copper clad aluminum.
- 5.1.3 Buried connectors shall be of type USE (or UF when protected as a feeder or branch circuit) and shall be buried at least 610mm (24 in.) below the ground surface. Wet rated conductors in non-metallic conduit are also acceptable for providing service.
- 5.2 Waterer installed near or in a building may be served by a branch circuit from the service equipment of the building.

- 5.1.3 Buried connectors shall be of type USE (or UF when protected as a feeder or branch circuit) and shall be buried at least 610mm (24 in.) below the ground surface. Wet rated conductors in non-metallic conduit are also acceptable for providing service.
- 5.2 Waterer installed near or in a building may be served by a branch circuit from the service equipment of the building.

6. Supply Circuits

- 6.1 Waterers installed within or near a building and served by a branch circuit from the service equipment of the building shall be connected as in Exhibit B.
 - 6.1.1 The equipment grounding conductor shall originate at the service equipment of the building.
 - 6.1.2 The equipment grounding conductor shall be connected to the equipment grounding terminal of the waterer and bonded to any intermediate enclosure or device that requires grounding. The equipment grounding conductor shall be isolated from the grounded (neutral) conductor at every point beyond service equipment.
- 6.2 An individual waterer installed in a lot and served by separate service equipment shall conform to the following: (see Exhibit C)
 - 6.2.1 Overhead conductors shall be firmly attached to support points and conform to 5.1.1 and 5.1.2. Buried conductors shall conform to 5.1.3.
 - 6.2.2 The incoming grounded conductor shall be bonded to the service equipment enclosure and to a grounding electrode conductor at the grounding bar in the service equipment. The grounding electrode conductor shall extend to a grounding electrode (a ground rod or other effective electrode).
 - 6.2.3 An equipment grounding conductor shall originate at this service equipment and shall be installed with the circuit conductors to the waterer.
 - 6.2.4 The equipment grounding conductor shall be installed as described in 6.1.2.

7. Multiple Installations

- 7.1 When more than one waterer is to be served from a central service, the service equipment should be located near the load center.
- 7.2 Each waterer shall be connected as specified in 6.2.

NOTE: THE USE OF THE RISER PIPE AS A GROUNDING MEANS IS NOT RECOMMENDED

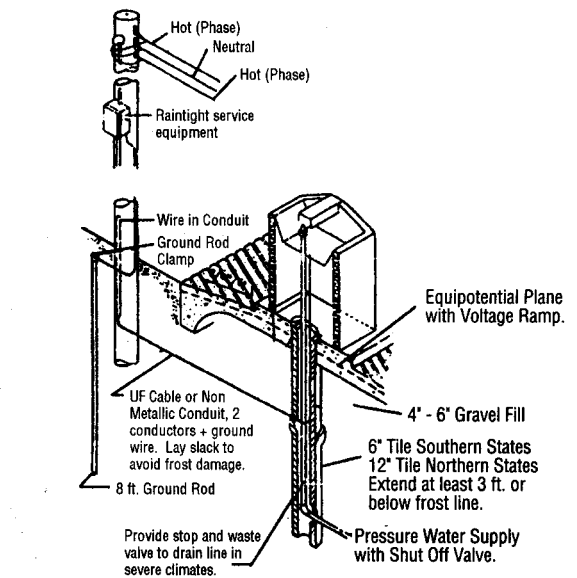
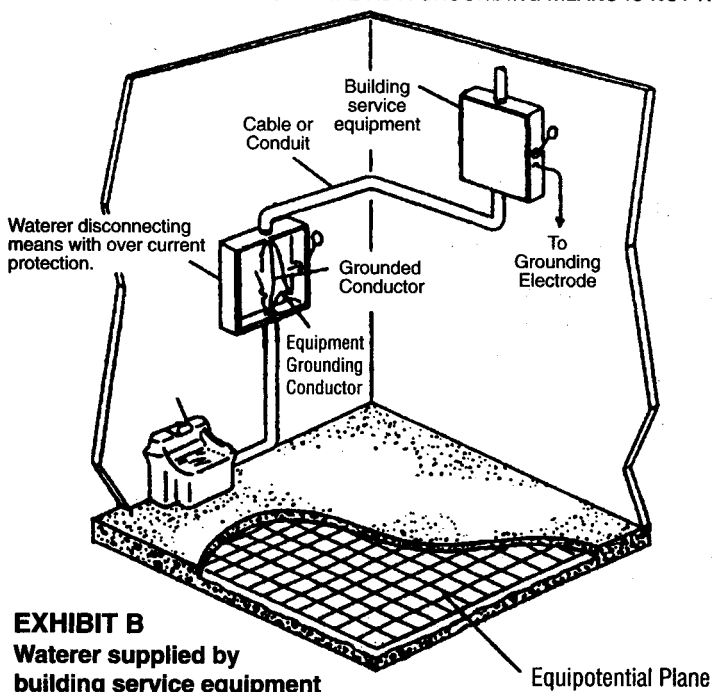

EXHIBIT C
Waterer supplied by its own service equipment

INSTALLATION INSTRUCTIONS

- STEP 1:** Get your qualified electrician involved in the planning of your installation. Review Exhibits A, B and C on page 2.
- STEP 2:** **RISER TILE** - The ideal size of riser depends on the installation, source of water and geography. If you are replacing an existing waterer and have had no supply line freezing problems and have been using no supplemental heat on your supply line, you can probably use your existing tile. For best protection, we recommend that a new riser tile of at least 8 inches (20.3 cm) diameter be installed. **INSTALLATION MUST BE MADE WITHOUT THE SUPPLY LINE TOUCHING THE RISER TILE AND THERE MUST BE NO DEBRIS OR DIRT IN THE RISER TILE. DO NOT STUFF YOUR RISER TILE WITH INSULATION AS IT CAN BECOME WATER LOGGED RESULTING IN FROST PENETRATION.** If the installation is north of Interstate 90 or if frost heaving is a problem in your area, use a flexible supply line, such as 3/4 inch (1.9 cm) braided vinyl tubing available at most plumbing supply outlets. If your water supply line is flexible and you are concerned that the flex may cause it to touch the riser tile, use a deep well submersible cable guard (a nylon plate that slips over the supply line and keeps it centered). Ask for a deep well submersible cable guard at your local plumbing supply outlet. We recommend using foam pipe insulation around your supply line (not provided). Make sure the insulation does not touch the riser tile as well. Where water is 54°F (12°C) or higher, you will probably not need to use a tile larger than 8 inches (20.3 cm) diameter. If entering water is 50°F (10°C) or colder, we recommend a tile of about 12 inches (30.5 cm) diameter. If incoming water has a temperature of the lower 40's (about 4°C), use a 14 inch (35.6 cm) tile.
- STEP 3:** **MOUNTING PAD** - Review Exhibit D. Concrete pad should be about 4 inches (10.2 cm) thick. Surface area where drinker sits should be smooth and level to provide a good seal. From the edge of the drinker, pad should slope about one-quarter inch per foot (about 1cm per 48 cm). The size of the pad is left to the user's discretion but we suggest you pour a pad large enough for livestock to stand on while drinking (about 19 inches (48 cm) beyond the edge of unit on all four sides). A rough broom finish provides better livestock footing. **NOTE:** The area where drinker sits should be smooth. A styrofoam barrier should be provided around the riser tile. Supply line should be at least 3/4 inch (1.9 cm) diameter. However, line should be sized to account for any pressure drop relating to distance. Water lines over 50 feet (15 meters) should be one inch (2.54 cm) or larger. Use of undersized supply line may cause loss of recovery capability. Attach a 3/4 inch (1.9 cm) N.P.T. female connector (not included) to your supply line. Make sure top of riser tile is flush with top of pad. Also, make sure the top of the female connector (not included) is flush with top of the pad. Connect the provided 3/4 inch (1.9 cm) STANDARD MPT to PVC adapter (Ref. No. 15). Glue 3/4 inch (1.9 cm) PVC tube (provided) to the STANDARD 3/4 inch (1.9 cm) MPT to PVC adapter (Ref. No. 15).
- STEP 4:** **HEATER ASSEMBLY** - Glue Ref. No. 23 Adapter onto the 14" long, 1-1/2" Schedule 40 PVC tube. Run your electrical supply into the 1-1/2" tube and install tube into the base with Ref. No. 15 O-Ring. Snap on Ref. No. 22 PVC Clip. This is used to help support the heater on the 14" tube. Move the clip to 4 inches off the bottom. Your C250 utility de-icer is supplied with the cord set plug clipped off. This permits a water tight connection. Cut the heater electrical cord to the desired length. The recommended length of the heater electrical cord is about 18 inches. Strip the three wires inside the heater cord set to connect to your supply line - black to hot; white to neutral; and green to ground.

- STEP 5:** **MOUNTING DRINKER** - Review Exhibit E.
1. If you are using it slide pipe insulation down over supply tube making it even with the top of the riser tile. Hold in place at the top with tywrap.
 2. Stick base seal to reservoir bottom just inside the anchor slots across the ends.
 3. Set reservoir over supply tube keeping supply tube centered in the tile.
 4. Run electrical supply into the heater assembly in the drinker.
 5. Anchor drinker at this time.
 6. Slip riser tube over supply tube and tighten into reservoir base. Make sure O-ring is in place on the riser tube.
- Review Exhibit F
7. Mark supply tube so that 1/2 inch (1.27 cm) extends above the top of riser tube and cut supply tube at mark. Removing riser tube before cutting supply tube may make this step easier. Glue MACHINED 3/4 inch (1.9 cm) MPT to PVC adapter (Ref. No. 12) to top of supply tube. Replace and tighten riser tube if you have removed it.
 8. Tighten slip joint nut, (Ref. No. 13) at top of riser tube, against the biggest diameter of the 3/4 inch (1.9 cm) MPT to PVC adapter (Ref. No. 12) on the supply tube. This should be centered on the smooth surface.
 9. Tighten 3/4 inch (1.9 cm) tee on supply tube with the pipe plug up.
 10. Lag drinker to pad. Use an anti-sieze compound on the lag bolt threads and nuts.
 11. Complete your electrical hookup.

EXHIBIT D

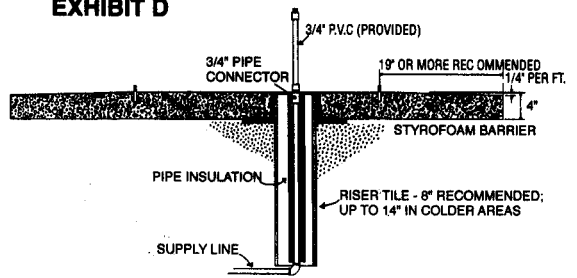

EXHIBIT E

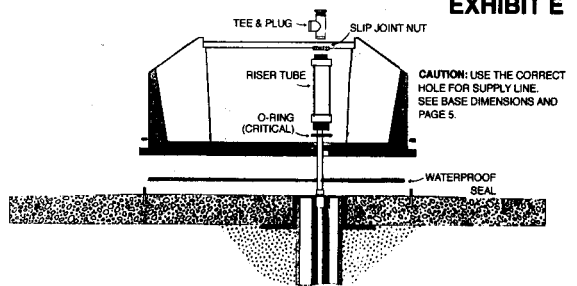

EXHIBIT F

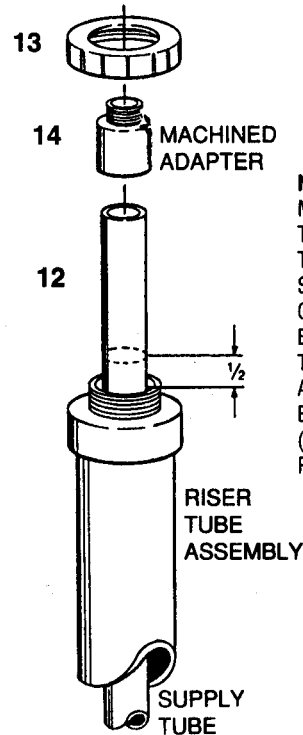
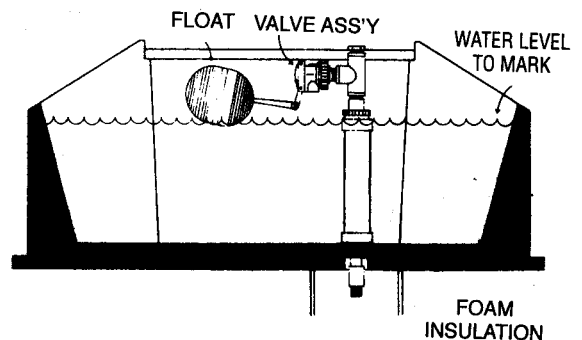

EXHIBIT G



STEP 6: MOUNTING THE VALVE - Review Exhibit G.

Adjust the float so the water fills the reservoir about 1 inch (2.54 cm) from overflow of the drink opening.

VALVE ADJUSTMENT: All our drinkers are equipped with valves with interchangeable orifices when shipped. This dependable valve has served our customers since 1975. The standard valve for your unit normally operates on a range of 20 to 60 psi. When your drinker is installed on a gravity flow or low pressure system, you may adjust your valve for more water volume by using a larger orifice. If your drinker is installed on a high pressure water system (over 60 pounds) you may compensate for extra pressure by using a smaller orifice. For severe high pressure situations, you may need to install a pressure regulator.

STEP 7: SPRING LOADED HEATED VALVE COVER (lid) - See Exhibit J. To lock the lid onto the base, place the lid into the body, aligning the stainless steel pegs on the lid with the tabs on the top surface of the base. With your 2 index fingers, depress the stainless steel pegs and push down on the lid. The pegs will snap into the holes in the tabs.

To remove the lid, take most any instrument such as a screwdriver, end of a pliers handle, even a key. Depress the peg through one tab and pull up on that side of this lid so that the peg is not in the hole. Hold that side of the lid (so that the peg is not in the hole) while depressing the peg on the other side. The valve cover should pop up and off the base.

VP VALVE CAPACITIES
Gallons per Minute
(Liters)

	VP114	VP16	VP17
PS	5/32" Orifice	1/4" Orifice	3/8" Orifice
20	2.44 (9.2)	3.70 (14.0)	5.00 (18.9)
40	3.70 (14.0)	6.25 (23.7)	8.33 (31.5)
60	4.55 (17.2)	7.69 (29.1)	9.62 (36.4)
80	5.00 (18.9)	7.94 (30.0)	9.62 (36.4)

Model VP114 5/32 inch orifice comes standard with Model VP123 valve.

Ref. No.	Part No.	Description	Qty.
1	VP19	Power Link	1
2	VP110	Cam Link	1
3	VP11	Valve Body	1
4	VP111	Link Pin	2
5	VP18	Plunger	1
6	VP113	Diaphragm, Rubber	1
7	VP114	Orifice, 5/32	1
8	VP112	O Ring 5/8 x .103 Neoprene	1
9	VP13	Base 3/4 OD x 1/4 ID, Plastic	1
10	VP15	Assembly Nut	1
11	VP115*	Adjust Screw	1
12	VA225P*	Float Arm Plastic	1

EXHIBIT H

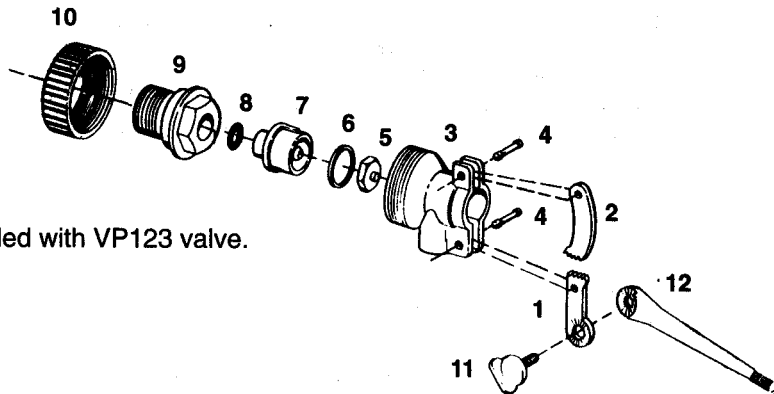

* VP115 and VA225P are not included with VP123 valve.

HEATER OPERATION:

WARNING

DISCONTINUE ELECTRICAL SERVICE TO ELECTRIC SUPPLY LINE
BEFORE REMOVING THE HEATER.

Farm Innovators Model C250 Utility De-Icer standard specifications are 250 Watts / 120 VAC / 2.0 AMPS. The heat range is about 34° F to 45° F. The de-icers only works when the temperature approaches freezing. It is thermostatically controlled to turn on at freezing and to turn off when the temperature is above freezing.

If unit freezes in the drinker due to the loss of power, allow unit adequate time to melt itself free. Do not chop or cut at unit while plugged in.

Low voltage is a possible cause for failure or poor performance. Measure voltage at receptacle with unit energized. Voltage drop means wattage reduction. Extension cords cause voltage drop and are unsafe.

IMPORTANT! DO NOT ALLOW DEPOSITS TO BUILD UP ON THE HEATING ELEMENT. This can cause "hot spots" which is a primary reason of failure and voids the warranty. White vinegar or "Lime Away" can be used to clean the tubular element.

When taking unit out of service, disconnect power supply cord, remove unit from tank, clean element (see above), store indoors.

Other Management Tips

For extra assurances that your supply line will not freeze up during the severest conditions:

1. Make sure you have an airtight and water tight connection between the mounting pad and drinker base.
2. Make sure your riser tile is flush with the top of the platform.
3. When tank needs to be cleaned, stir up solids so they are in suspension. Remove plugs (or push in plugs through outside openings). The valve will activate giving a flushing action.
4. When servicing during cold weather, use artificial inseminator's plastic sleeve to keep hands and clothing dry.

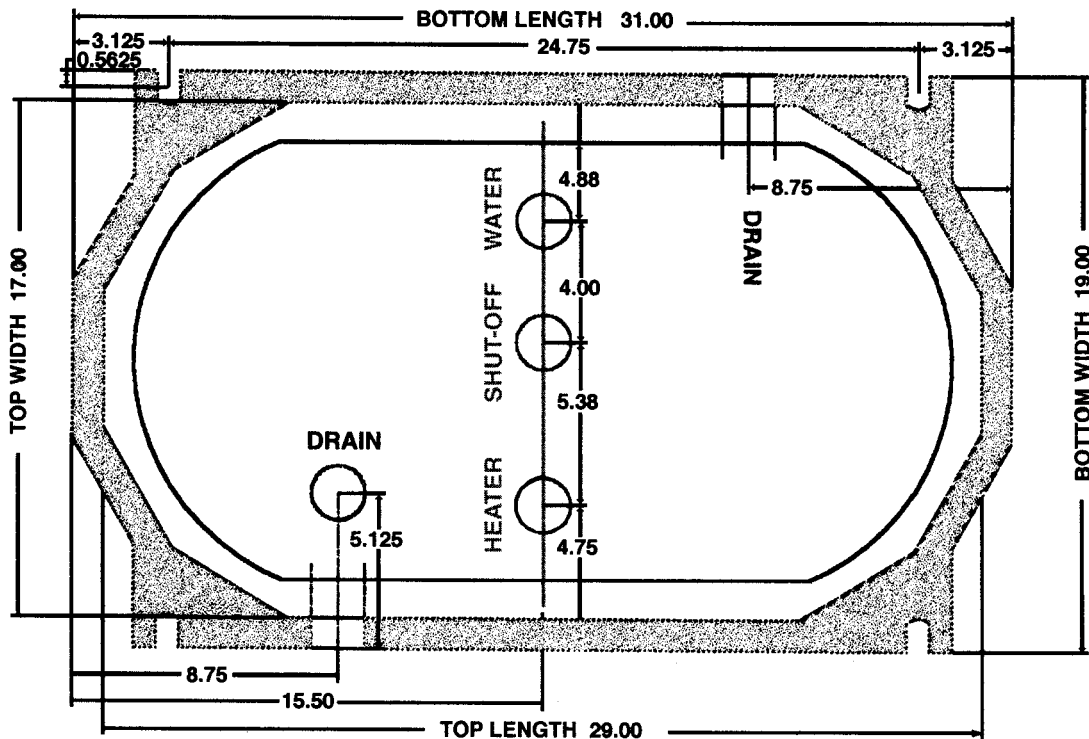

EXHIBIT I
TOP DOWN VIEW OF WPO17/MPO17
Base Dimensions in inches

LIMITED WARRANTY

Our part no. OP284 C250 Utility Deicer (heater) and our DURAPRIDE Valve (including float arm, float and adjust screw) carry an 18 month limited warranty. All other components of Hawkeye Steel Products, Inc. Performance One E-Drinks are covered by a five year limited warranty. Both warranty periods are from the date of purchase. Each drinker must be registered with Hawkeye Steel Products, Inc. on the card which accompanies each drinker. Warranted components should be returned to your dealer for shipment to our factory -- Highway 16 West, P.O. Box 2000, Houghton, IA 52631 USA, Fax 319-469-4402; 800-553-1791. Warranty is limited to the repair or replacement of components. The warranty does not cover removal or reinstallation; cost to transport and retrieve components for repair; damage or loss occurring during transport; damage due to foundation design; damage caused by natural or environmental conditions (acts of God); costs associated with loss of time and/or inconvenience or any other consequential damages; injury; lack of animal performance; loss of profit; life of property; malfunction resulting from misuse, improper installation, lack of maintenance (such as not periodically removing deposits on the deicer), unauthorized alteration, or negligence. All provisions stated on the back of Hawkeye Steel Products, Inc.'s invoice apply and Hawkeye Steel Products, Inc. assumes no consequential damages.

