



READ THIS FIRST
Instruction Sheet - suggestions for using
the Roto Clip Trimming Disc

1. Safety First - use protective eye wear. Check your equipment, keep guards and shields in place.
2. Attach the roto clip disc to a 4-1/2" - 5" hand grinder as shown on FIG. A.
3. Make sure the flange nut of the grinder is secure and tight so that the torque of the motor does not tighten the flange nut.
4. Now that the roto clip disc is mounted against the clamping flange and true to the spindle, as shown in FIG. A, you are ready to trim with the roto clip disc. If you have never used the disc before, you may want to experiment on a block of wood in order to obtain some idea and a feel of how the disc cuts and reacts (FIG. B).
5. Wear protective gloves and eyewear, keep both hands on the grinder, and secure item to be worked on. Maintain a slight angle to the work as shown in FIG. B. Make sure that only a portion of the disc makes contact with the material to be trimmed or shaped. If the disc is flat to the work, it may grab and the disc will react different than if you were grinding with a regular grinding wheel. **Important notice for persons using disc for hoof trimming:** user should have a knowledge of the hoof structure and makeup of animal they want to trim.
6. Best results are obtained by trimming with a flow of direction with the grain of item being worked on (FIG. C). For hoof trimmers: trying to start on the front of the claw and moving toward the heel may cause the disc to grab. You can trim in between the claws and around the shell of the hoof, but remember the heel to the front, flow of direction.
7. You need not apply pressure, just guide the grinder and let it do the work.
8. When the disc becomes dull, do not continue use. If you continue to use while dull, you will reduce the life of the disc more rapidly and disc may start to grab.
9. To sharpen the original disc, place the carbide burr in a wood router (FIG. D). Take disc with the hub down, and place the carbide burr up through the cutting slot. Pull the disc against the burr and move from one end to the other making sure the hub is flat against the top of the sharpener or router table. Do not overheat the cutting edge with the carbide burr. This will destroy the cutting edge.
10. To sharpen carbide disc remove inserts and return to Roto-Clip Inc. Any Questions Feel Free to Phone.

FIG. A

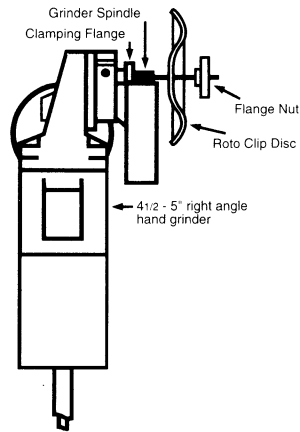

FIG. B

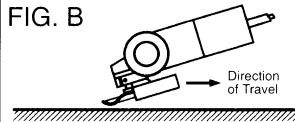

FIG. C

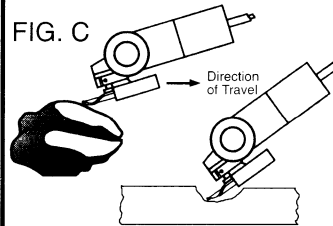
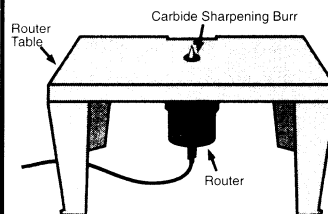

FIG. D



ROTO-CLIP INC.
 81 East 1850 North
 Logan, Utah 84341

Or Phone
 Toll Free

1-800-843-3912 or
1-435-752-0968

FAX 1-435-752-0935

web site - <http://www.rotoclipinc.com>

US and Canadian Patent