



**Model
#3390E
Beef - Dairy
Waterer
Electric**

#3390E Specifications

2 - 10" openings / Ball closures / Electric

Capacity	Gallons	Dimensions	Weight
150 Hd. Beef 60 Hd. Dairy	44 (166.5 Liters)	43" x 29" x 20" tall (109 x 73.6 x 51 cm)	129# (57 Kg)

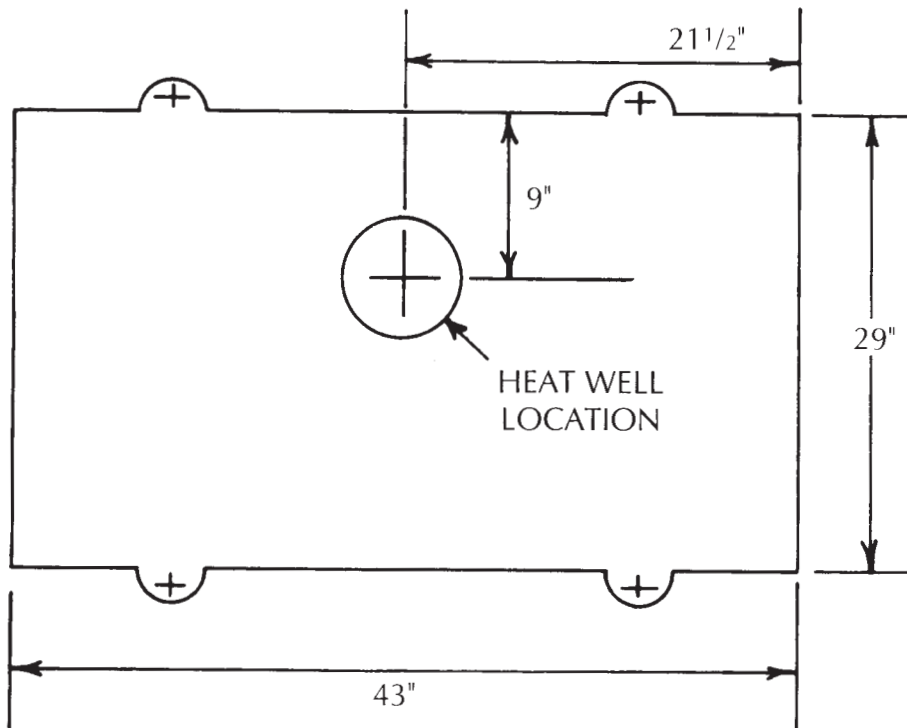

We recommend all anchor bolts be drilled in after the tank is set because dimensions may vary.

PARTS PRICE LIST FOR #3390E

Founts manufactured before May 2016 use Part #673 - 3/4" Special "T" (\$11.55) in place of Part #672

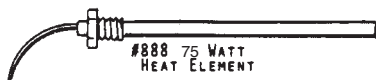
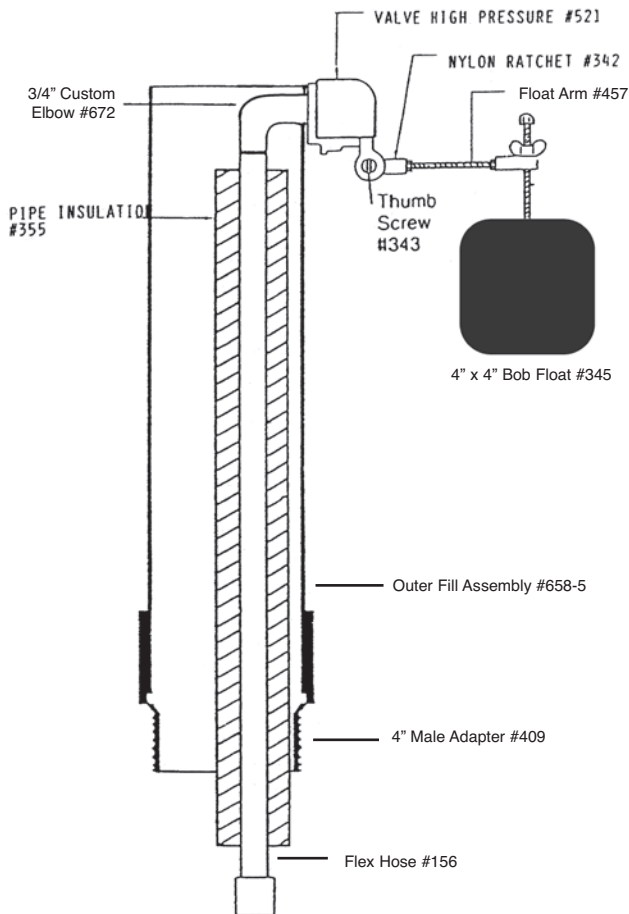

Part #	Description
969	Top assembly complete
968	Center insert complete
779	Center insert w/o dome
688	End insert
967	Center dome 55"
876	Center dome gasket
862	Top gasket assembly 141"
306	5/16" x 2" S.S. bolt
878	5/16" S.S. washer
643	10 3/4" drinker ball
965	Base assembly complete
347	5/16" x 3/4" S.S. washer
409	4" male adapter
706	5/16" x 2 1/2" S.S. lag bolt
658-5	Outer fill pipe
887	Thermostat*
888	Heat element*
889	1/4" x 1 1/4" Truss H.D. bolt
886	Inspection cap
890	Inspection cap gasket
893	Wire connector
694-5	#3390E parts bag
761	5/16" x 4" bolt
322	2" rubber drain plug
344	3/8" x 3 3/4" S.S. anchor bolt
351	3/8" S.S. washer
352	5/16" x 1" S.S. bolt
353	Anchor clip
699	3/8" S.S. nut
667	Anti syphon device
480	Bottom gasket 137"
919	Heat cable*
440	Valve assembly
521	Valve high pressure
672	3/4" custom elbow
458	Float assembly
342	Nylon ratchet
343	Brass thumb screw
345	4" x 4" bob float
457	Float arm
156	2' Flex Hose
355	Pipe insulation
400	Hose Clamp
396	3/4" Male x barb fitting